

FEMTOSECONDS LASER PUMP-PROBE FOR NANOROUGHNESS ANALYSIS

Rumen Ivanov^{1,2}, Jesús Villa², María Araiza², Daniel Alaniz², Ernesto Marín³, Cuauhtémoc Araujo¹ and Victor M. Castaño⁴

¹Facultad de Física, Universidad Autónoma de Zacatecas, Calzada Solidaridad, Esquina Paseo de la Bufa s/n, C. P. 98060, Zacatecas, Zac., México

²Facultad de Ingeniería Eléctrica, Universidad Autónoma de Zacatecas, Avenida Ramón López Velarde 801, Zacatecas 98000, México

³Centro de Investigación en Ciencia Aplicada y Tecnología Avanzada, Instituto Politécnico Nacional, Legaria 694, Colonia Irrigación, C. P. 11500, México D. F., México

⁴Centro de Física Aplicada y Tecnología Avanzada, Universidad Nacional Autónoma de México, Boulevard Juriquilla 3001, Santiago de Querétaro, C.P. 76230, Querétaro, México.

On sabbatical leave at CIATEQ-Queretaro

Received: February 02, 2014

Abstract. A novel differential technique of femtoseconds pump-probe laser beam to test energy transport properties of nanomaterials, based on an electro-optic device, is presented. As opposed to the standard methods, ours allows the modulation of the probe-beam. As will be shown, the differential method overcomes the drawbacks of the existing technologies for nanomaterials. These drawbacks includes the time resolution of the collected data, the signal to noise ratio and the time to record the reflectance data.

1. INTRODUCTION

The energy transport properties of materials have been widely studied by means of the pump-probe beam method with femtoseconds pulsed lasers [1-4]. There are two main drawbacks in the traditional techniques reported [1]: (1) the time resolution is equal or lower than the pump-beam period; (2) when rough samples are studied, scattered light cannot be completely eliminated, which causes a low signal to noise ratio, which is a limiting factor even when analyzing nanomaterials, in which several transport processes take place in pico and nanoseconds [2] so that very fast techniques are needed to study them, e.g. femtoseconds methods. Some methods [5-11] have been proposed to improve that, however, they have resulted expensive and they do not completely eliminate the drawbacks. In [12], the proposed differential method eliminates the above

mentioned limitations, however it is slow because the frequency modulation of the pump-beam is, at the most 1 KHz (in the method reported in [1] is 1 MHz), so that the time to record the reflectance data is very large. Accordingly, we propose a new differential method that uses electro-optic devices to substantially increase the frequency modulation of the pump-beam.

2. THE DIFFERENTIAL METHOD

The experimental setup for the proposed differential method is shown in Fig. 1. The main difference with the construction described previously [12] is in the design of the delay system together with its drivers. This system can work at 1 MHz using adequate acousto-optic modulators (AOMs, all beam splitters may be MT-80-IR, Electro-Optical Products Corporation, with carrier frequency of 80 MHz, rise

Corresponding author: Victor M. Castano, e-mail: victor.m.castano@gmail.com

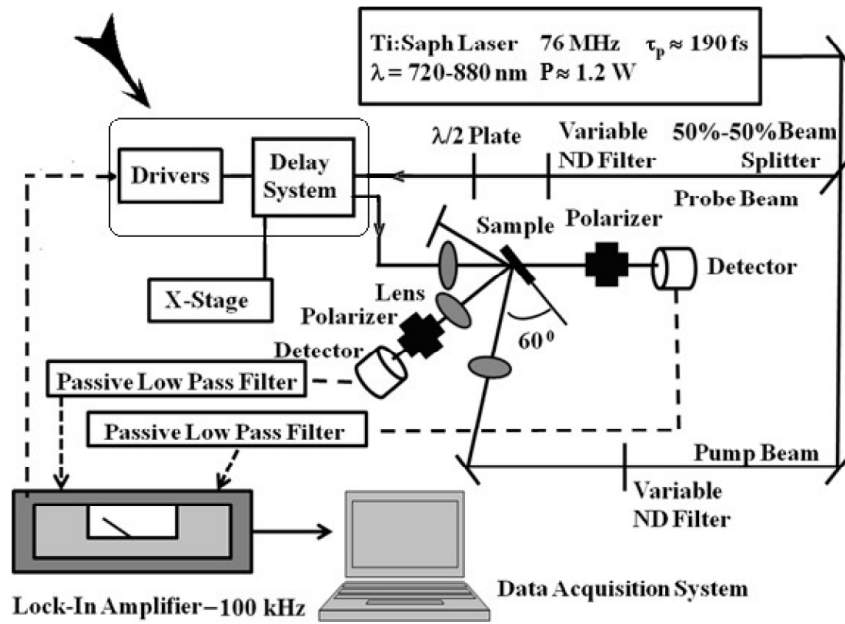

Fig. 1. Experimental setup for the proposed pump-probe beam method.

and fall times of 23 ns, switching frequency ≤ 1 MHz), however, to use a low-frequency lock-in amplifier (LIA) (for example, SR830, Stanford Research Systems) we restrict the frequency to 100 KHz, just to illustrate it. We suggest the use of low noise detectors (for example, FDS100-CAL, Thorlabs), and low-pass filters with a cut off frequency of 150 KHz.

The total time delay of the probe-beam is achieved by means of the x-stage (0 - 3 ns, resolution of 10 fs) and the delay oscillating system (delay of 10 fs - 1ps, resolution of 0.1 fs, which corresponds to 3 - 300 μm with a resolution of 30 nm). The delay system is coupled with the x-stage and it uses optical devices that do not deform the pulse shape.

2.1. The delay system

In Fig. 2 we show a diagram of the delay system. The system is divided in two branches. The probe-beam is divided by means of the input beam splitter. Both beams cross the AOMs (AOM1 and AOM2, respectively), which work in anti-phase mode. The corresponding drivers (for example MOD-80-2W, Electro-Optical Products Corporation) are synchronized with the TTL output of the LIA (for AOM1) and the logic inversion of the TTL (for AOM2). Each beam crosses a beam-splitter, the transmitted beams are directed to the Hollow Retroreflectors (for example, Broadband Hollow Retroreflector, model: UBBR2.5-1S, Newport) and return to the beam-splitters. The Hollow Retroreflectors are moved by mean of the x-stages and the piezo-actuators (for example, NF15AP25, Thorlabs, with driver MDT 694A,

Thorlabs). The beams cross an attenuator (A1 or A2) (for example, M63-048, Edmund Optics) to equalize their power. The $\lambda/2$ plates (for example, WPH05M-780, Thorlabs) adjust the polarization planes of both beams. The beams are added by mean of the output beam-splitter. Finally, the output polarizer ensures the polarization plane of the output beam not to change with the delay change.

The optical path difference of Branch 1 and Branch 2 (which causes the oscillating difference between delays) can be adjusted moving the hollow retroreflectors with a resolution of 25 nm. In Fig. 3 we show the graphs of the oscillating delay and the control voltage of the AOMs (Supposing a larger optical path in Branch 1).

As can be seen in Fig. 3, voltages of AOMs are opposite in phase. The delay system works as follows: for the lapse of time 0 - 5 μs the AOM1 is open while AOM2 is close (no beam passes through branch 2). The beam that crosses AOM1 goes to branch 1 and the pulsed beam is delayed according to the position of the Hollow Retroreflector 1. After the beam splitter (output) the beam is part of the probe beam. For the period of time 5 - 10 μs the AOM2 is open while AOM1 is closed (no beam passes trough branch 1). The beam that crosses AOM2 goes to branch 2 and the pulsed beam is delayed according to the position of the Hollow Retroreflector 2. After the beam splitter (output) the beam is part of the probe beam, and so on. This alternating process in AOMs forms the oscillating delay of the probe-beam (in Fig. 3 is called AC delay). The

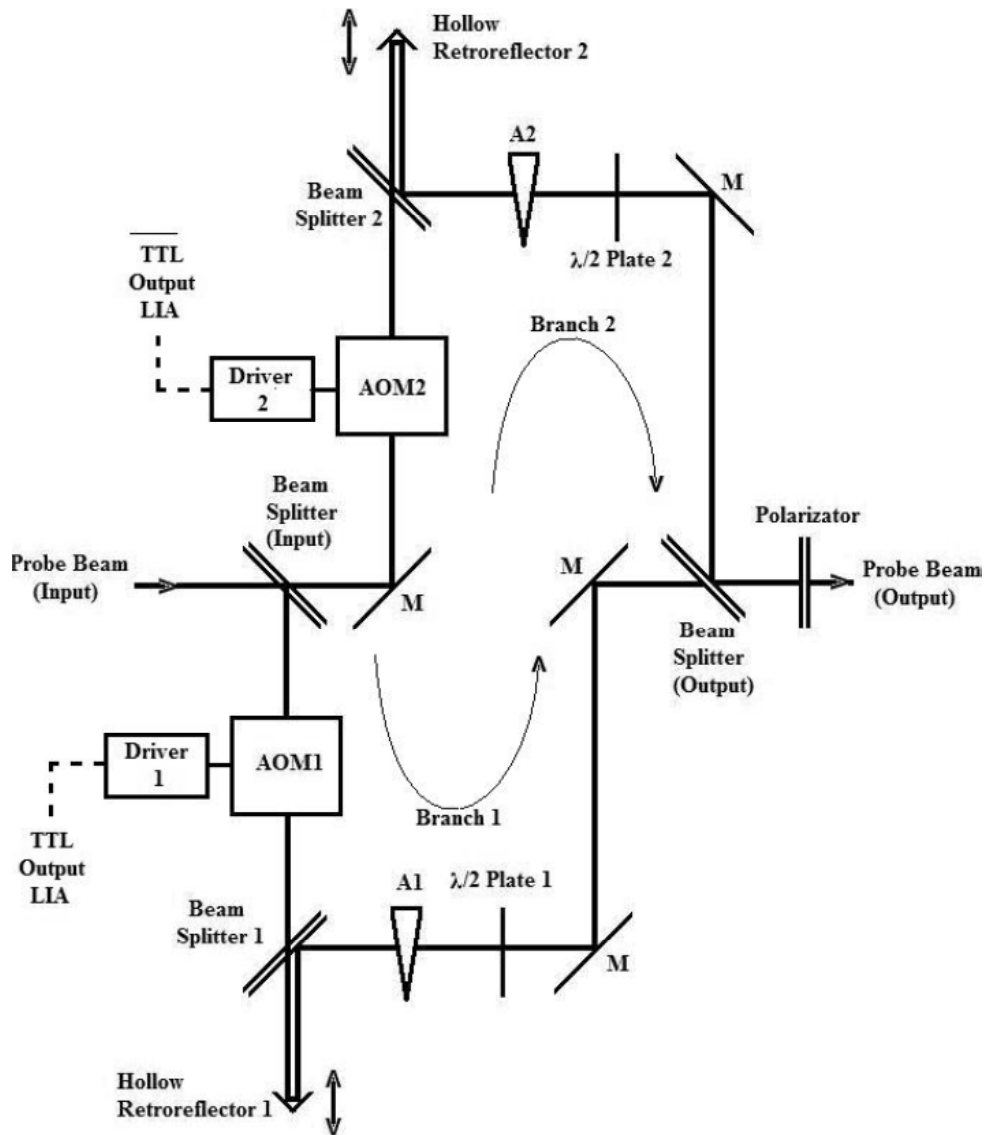

Fig. 2. Diagram of the delay system with opto-electronic devices.

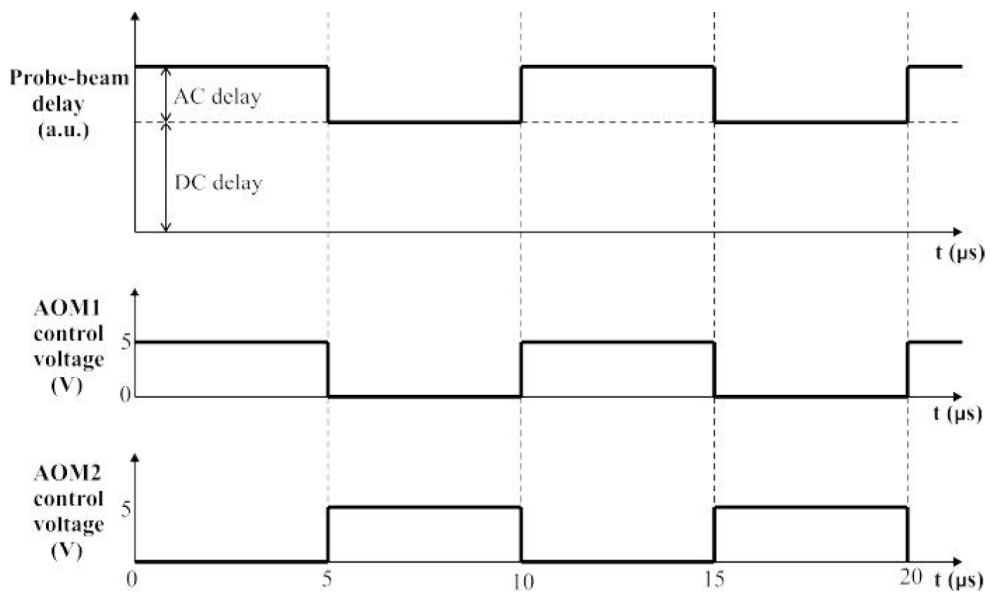

Fig. 3. Graphs of the delay and the control voltage in the AOMs. The DC delay is caused by the x-stage position, the AC delay is caused by the delay system.

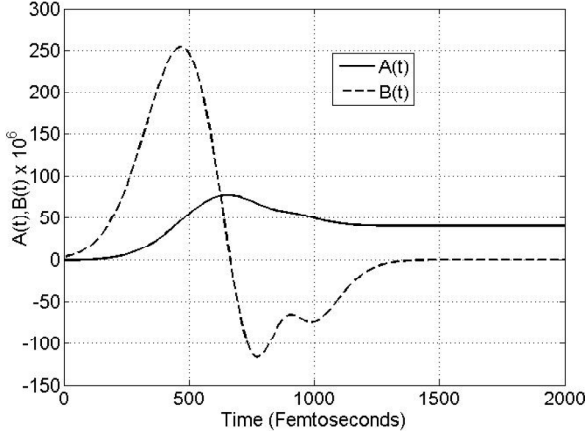

Fig. 4. Theoretical graphs of $A(t)$ and $B(t)$. Reflectance data have been used with the permission of the authors of Ref. [1].

frequency of the oscillating delay depends on the lock-in's synchronization which controls the AOMs through the drivers.

3. DETERMINATION OF THE REFLECTANCE DATA CURVE

We now describe a simpler algorithm to determine the reflectance data curve $DR(t)$. As described in [12], data $A(t) = DR(t)$ is encoded in the Lock-in's output voltage $B(t)$ (see [12] for details):

$$B(t_{i+1}) \approx \int_{t_i - 5\sigma}^{t_{i+1} - 5\sigma} G_{i+1}(t) A(t) dt, \quad (1)$$

where $i = 0, 1, 2, \dots, m-1$ and

$$G_{i+1}(t) = \exp\left[-\frac{(t - t_{i+1})^2}{2\sigma^2}\right] + \exp\left[-\frac{(t - t_i)^2}{2\sigma^2}\right]. \quad (2)$$

Considering that adjacent points $(t_i, A(t_i))$ and $(t_{i+1}, A(t_{i+1}))$ one can approximate a linear segment, then we know that

$$A(t_{i+1}) = A(t_i) + a_{i+1} (t_{i+1} - t_i). \quad (3)$$

Therefore, Eq. (1) can be written as

$$B(t_{i+1}) \approx A(t_i) \int_{t_i - 5\sigma}^{t_{i+1} - 5\sigma} G_{i+1}(t) dt + a_{i+1} \int_{t_i - 5\sigma}^{t_{i+1} - 5\sigma} G_{i+1}(t) t dt \quad (4)$$

and

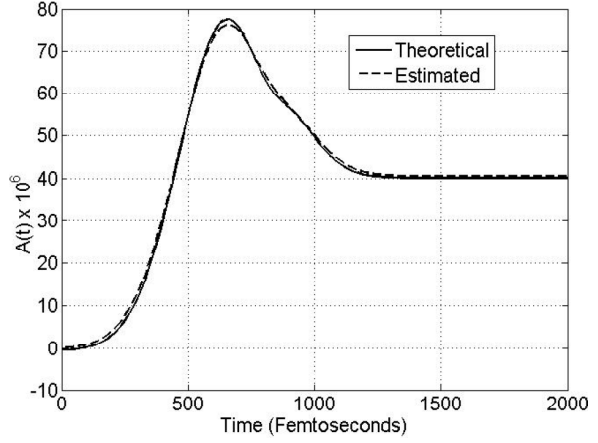

Fig. 5. Graphs of the theoretical and recovered $A(t)$.

$$a_{i+1} = \frac{B(t_{i+1}) - A(t_i) \int_{t_i - 5\sigma}^{t_{i+1} - 5\sigma} G_{i+1}(t) dt}{\int_{t_i - 5\sigma}^{t_{i+1} - 5\sigma} G_{i+1}(t) t dt}. \quad (5)$$

Once collected the measured data $B(t)$ and knowing that $A(t_0) = B(t_0) = 0$, the reflectance data set $A(t)$ can be computed with a simple loop using Eqs. (5) and (3).

We now present a numerical experiment for the estimation of the reflectance data $A(t)$ as in the experiment shown in [1], which represents the optical reflection of the surface under test, for example the theoretical plot corresponding to photon wavelength equal to 757 nm (see reference [1]). Fig. 4 shows the plots of the theoretical $A(t)$ and $B(t)$ with $m = 201$. In this case $t_{i+1} - t_i = 10$ (fs) and $\sigma = 100/2.35$ (fs). Fig. 5 shows the plots of the theoretical and the recovered $A(t)$.

4. CONCLUSIONS

A new differential method for pump-probe beam examination of energy transport properties of nanomaterials was developed. Unlike some traditional methods, in a differential method the time resolution of the collected data is high, and it presents a higher signal to noise ratio. Additionally, in this proposal the modulation of the probe-beam is carried out by means of opto-electronic devices, which increases the modulation frequency compared with the differential method reported in [12]. Consequently, the time to measure each value to build the reflectance graph is considerably reduced. We also

proposed an algorithm to estimate the reflectance data from the Lock-in's output voltage. Finally, our results could also be relevant to the growing and important area of tribology [13-15], if a better understanding of the mechanisms, both at micro and nanoscales, is to be achieved in that relevant area of applied Materials Science.

ACKNOWLEDGEMENTS

The support from CONACyT is greatly acknowledged. Author E. Marin additionally thanks the support by research grants SIP-IPN 1638 and 20140006 and CONACyT-83289, as well as the support from COFAA-IPN through the SIBE program.

REFERENCES

- [1] P.M. Norris, A.P. Caffrey, R.J. Stevens, J.M. Klopf, J.T. McLeskey Jr. and A.N. Smith // *Rev. Sci. Instrum.* **74** (2003) 400.
- [2] G.A. Antonelli, B. Perrin, B.C. Daly and D.G. Cahill // *MRS Bull.* **31** (2006) 607.
- [3] K.L. Hall, G. Lenz, E.P. Ippen and G. Raybon // *Opt. Lett.* **17** (1992) 874.
- [4] K. Yokoyama, C. Silva, D.H. Son, P.K. Walkout and P.F. Barbara // *J. Phys. Chem. A* **102** (1998) 6957.
- [5] H. C- Wang, Y.C. Lu, C.Y. Chen, C.Y. Chi, S.C. Chin and C.C. Yang // *Opt. Express* **13** (2005) 5245.
- [6] J. Zhang, A. Belousov, J. Karpinski, B. Batlogg and R. Sobolewski // *Journal of Physics: Conference Series* **193** (2009) 012058.
- [7] R. Illingworth and I.S. Ruddock // *Appl. Phys. B: Lasers and Optics* **29** (1982) 135.
- [8] S.V. Rao, D. Swain and S.P. Tewar, In: *Proc. of SPIE (7599)* (2010), 75991P1-8.
- [9] A. Yu, X. Ye, D. Ionascu, W. Cao and P.M. Champion // *Rev. Sci. Instr.* **75** (2005) 114301.
- [10] K. Kang, Y.K. Koh, C. Chiritescu, X. Zheng and David G. Cahill // *Rev. of Sci. Instr.* **79** (2008) 114901.
- [11] B. Bousquet, L. Canioni, J. Plantard and L. Sarger // *Appl. Phys. B: Lasers and Optics* **68** (1999) 689.
- [12] R. Ivanov, Jesus Villa, Ismael de la Rosa and E. Marin // *Optics Express* **19** (2011) 11290.
- [13] W. Brostow, J.-L. Deborde, M. Jaklewicz and P. Olszynski // *J. Mater. Ed.* **25** (2003) 119.
- [14] N.K. Myshkin, M.I. Petrokovets and A.V. Kovalev // *Tribology Internat.* **38** (2005) 910.
- [15] W. Brostow, V. Kovacevic, D. Vrsaljko and J. Whitworth // *J. Mater.* **32** (2010) 273.